

MICROMECHANICS (C236/C214)

HOMEWORK VIII (due next friday)

Problem 1:

Assume plane strain condition. The Airy's stress function solution for an edge dislocation is:

$$\Phi = -\frac{\mu b y}{4\pi(1-\nu)} \ln(x^2 + y^2) \quad (1)$$

- (a) Show that $\nabla^2 \nabla^2 \Phi = 0$;
 (b) Find stresses, $\sigma_{xx}, \sigma_{xy}, \sigma_{yy}$;
 (c) Find strains, $\epsilon_{xx}, \epsilon_{xy}$, and ϵ_{yy}
 (d) Show that

$$\int_{-\infty}^{\infty} [\epsilon_{xx}(x, y) - \epsilon_{xx}(x, -y)] dx = -b, \quad y \rightarrow 0, y > 0 \quad (2)$$

Hint:

$\mu = G = \frac{E}{2(1+\nu)}$ is the shear modulus, and

$$\int_{-\infty}^{\infty} \frac{dx}{(x^2 + 1)^2} = \frac{\pi}{2} \quad (3)$$

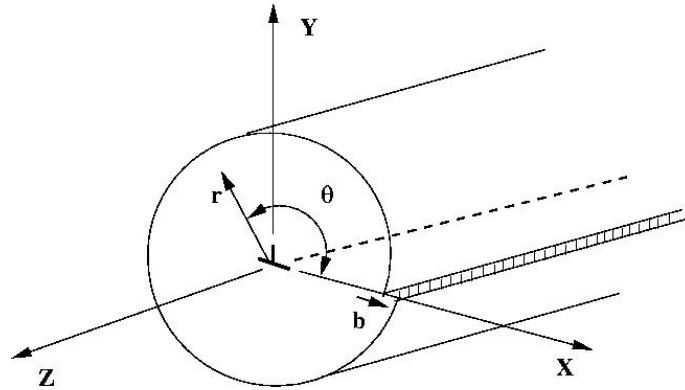

Figure 1: An edge dislocation

Problem 2.

Calculate the self-energy (per unit length) of an edge dislocation in a finite region: $0 \leq z \leq L$, $r_0 \leq r \leq R$, and $0 \leq \theta < 2\pi$. Neglect the core energy.

Hint: use polar coordinate.

Hirth and Lothe, "Theory of Dislocation," 2nd Edition, Krieger Publishing Co.

Problem 3.

A screw dislocation is placed eccentrically in a cylinder, and its distance from the center is ξ_1 . To satisfy the traction-free boundary condition at cylinder surface, an image screw dislocation is placed outside of the cylinder with horizontal position $\xi_2 = R^2/\xi_1$, where R is the radius of the cylinder.

Show that (1)

$$w = \frac{b}{2\pi} \left(\tan^{-1} \frac{y}{x - \xi_1} - \tan^{-1} \frac{y}{x - \xi_2} \right) \quad (4)$$

is the solution of the problem, i.e. satisfying both the differential equation and the boundary condition;

(2) Find the strain energy per unit length for the total solution.

Hint:

Eshelby, J. : "Screw dislocation in thin rods," *Journal of Applied Physics*, Vol. 24, pp. 174-179.

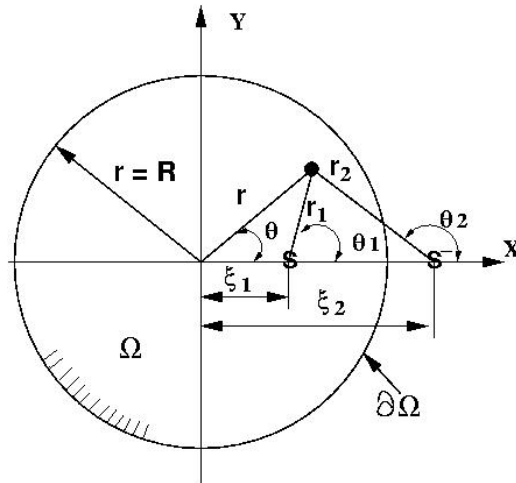

Figure 2: Problem 3: An eccentric dislocation with image dislocation.