

Steel-free Deck Slab Construction in Bridges

The application of Fiber Reinforced Polymers (FRP)
in concrete

Tracy Coughlin

April 1, 2004

CE247 Concrete Technology

Problem: Deteriorating Bridges

- Damage or deterioration due to corrosion of steel reinforcement present in the concrete deck slab
- The harsh climates of Canada and U.S. accelerate the corrosion process
 - Freeze-thaw cycles
 - De-icing road salts
- Costly to repair





Solution: Eliminate steel from deck slab

Two new technologies:

1. Steel-free deck slab consisting of composite fiber reinforced concrete (FRC)
2. Steel-free deck slab utilizing fiber reinforced polymer (FRP) reinforcing bars

1. Steel-free FRC deck slab

- No internal reinforcing steel
- Strength from compressive arch within deck slab between girders
- Arching action achieved by:
 - Transverse confinement provided by external steel straps
 - Longitudinal confinement provided by making slab composite with beams
- Punching shear behavior achieves higher failure load than flexural behavior

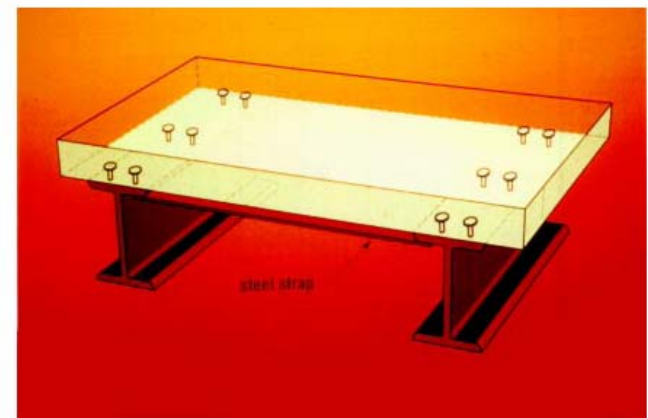
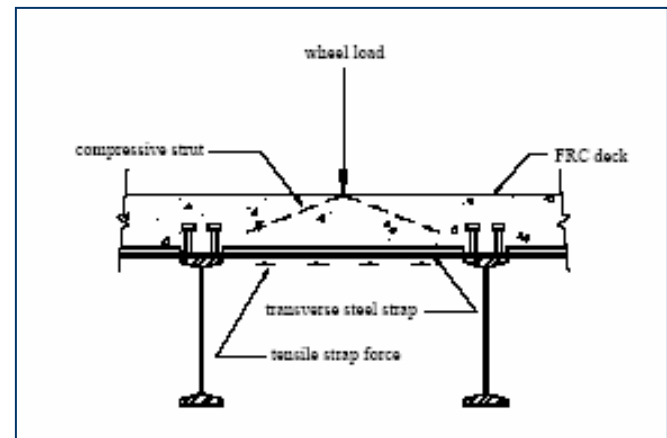

FRC deck slabs – research & development

- Full-scale tests confirmed that FRC decks had very high fatigue and static strength
- Importance of connecting concrete barrier wall to the slab
- Glass FRP more economical than carbon FRP
- Reduce spacing of the two outer girders
- Reduce length of deck slab overhang
- Considerable savings in construction
 - Eliminated cost of steel reinforcement
 - Decreased labor required

The Salmon River Bridge (Canada 1995)

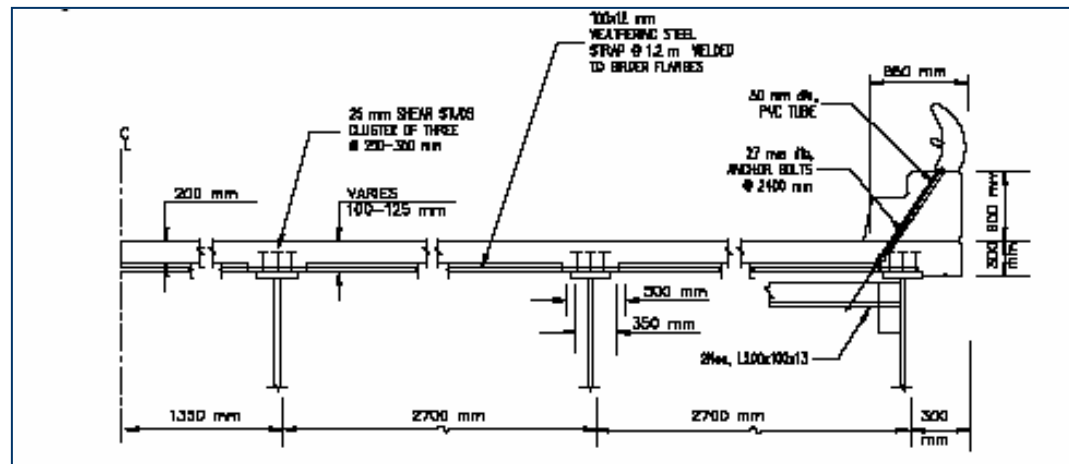

- 0.55% chopped polypropylene fibers
 - Reduced from 0.8% in the original mix design to allow easier pumping
- Utilizes steel-straps for confinement
- Concrete barriers have steel rods encased in PVC tubing to transfer impact loads from barrier walls to girders

The Salmon River Bridge - evaluation

- Two independent spans allow for comparison of traditional and FRC construction
- No deficiencies found in either span
- No signs of deterioration after exposure to harsh environmental conditions
- FRC construction about 6% more costly than conventional construction
- FRC construction eliminates long-term costs due to corrosion and extends life of structure



2. FRP reinforcing bars



- Fiber Reinforced Polymer (FRP) reinforcing bars developed in the U.S.
 - Fiber (Glass, carbon, or aramid) + resin
- High strength
- Resistant to corrosion

McKinleyville Bridge (West Virginia 1996)

- 229 mm. deck slab thickness
- No. 4 FRP reinforcing bars, No. 3 FRP ties
- 75% carbon fiber, 25% resin
- Changes observed in construction:
 - FRP bars lighter and easier to handle
 - Spacing of chairs decreased to support more flexible FRP bars
 - To avoid flotation of FRP bars, necessary to tie them down to formwork
- Deflections and stresses found to be well within allowable limits



CONCLUSIONS



- No deficiencies found in steel-free FRP construction
- FRP applications more economical on a Life Cycle Cost basis
- Additional research and investigation needed
 - Creep, fatigue, durability, bond, and strength of FRC slabs
 - Durability, cracking and deflection of concrete, bond, temperature effects, and mechanical properties of FRP reinforcing bars
 - Long-term behavior unknown
- Design criteria and standards needed